

EVO™ 5507

Straight-Reach LCD Arm



Model 5507 from the EVO™ Series is an attractive arm suited for both desktop and wall or function wall mounting. The arm allows effortless height adjustment and repositioning of the monitor. EVO™ creates a multi-functional workspace where the monitor can be moved out of the way when not in use.



FEATURES

- ▲ Intuitive movement — no buttons or levers, simply move monitor to desired position
- ▲ Quick-install/quick-release mechanism instantly and securely snaps monitors into position
- ▲ Mount clamps to desk or through grommet with integrated handle (*other options available separately*)
- ▲ Cable management reduces workspace clutter



Vertical range of +/- 12cm from horizontal



Extends 46cm and folds flat to save maximum space



Quick-install/quick-release



Integrated cable management

Phone: 1300 798 050 | Fax: 1300 798 052 | E-mail: enquiry@lcdmonitorarms.com.au | Web: www.lcdmonitorarms.com.au

EVO™ 5507

Specifications

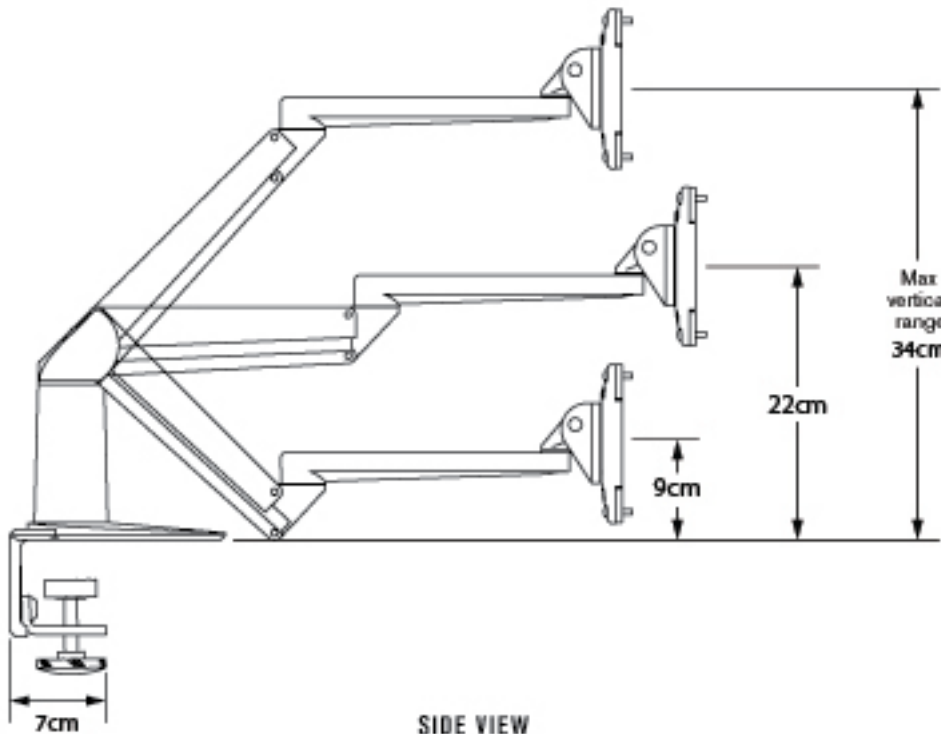

SIDE VIEW
Vertical Range

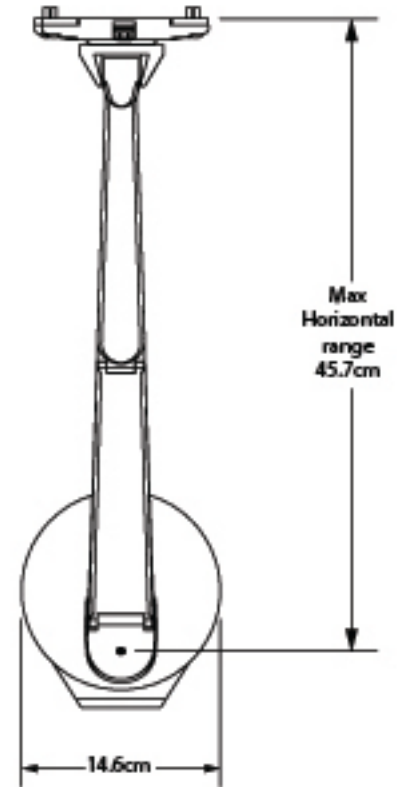

TOP VIEW
Horizontal Range

- Vertical range: +/- 12cm from horizontal
- Horizontal range: 46cm
- Rotation: 360 degrees at three joints
- Monitor tilt: 185 degrees
- Monitor pivot: Landscape to portrait
- Monitor compatibility: VESA® MIS-D, 100/75, C compliant
- Cable management: Cables are clipped beneath arm
- Mounting options: Desk clamp (5cm thickness or less)
Grommet mount (5cm or larger)
Function Wall and Wall bracket (sold separately)
- Monitor weight: 2.7 - 5.9 kg

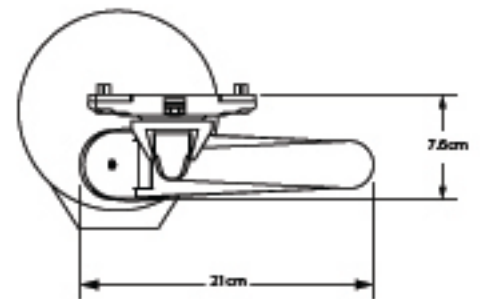

TOP VIEW
Arm Folded