

EVO™ 5545



reddot design award
winner 2006



Ergonomics made beautiful... EVO™ establishes a new standard in computer ergonomics by delivering elegant yet functional design to the desktop. EVO™ levitates a flat panel monitor above the work surface, enabling intuitive fingertip adjustment of monitor height and position. EVO™ creates a multi-functional workspace where the monitor can be moved out of the way when not in use.



FEATURES

- ▲ Intuitive movement — no buttons or levers, simply move monitor to desired position
- ▲ Quick-install/quick-release mechanism instantly and securely snaps monitors into position
- ▲ Mount clamps to desk or through grommet with integrated handle
- ▲ Cable management reduces workspace clutter



Vertical range of +/- 5" from horizontal



Folds flat to save maximum space



Quick-install/quick-release



Integrated cable management

Phone: 1300 798 050 | Fax: 1300 798 052 | E-mail: enquiry@lcdmonitorarms.com.au | Web: www.lcdmonitorarms.com.au

TM
EVO 5545
 Specifications

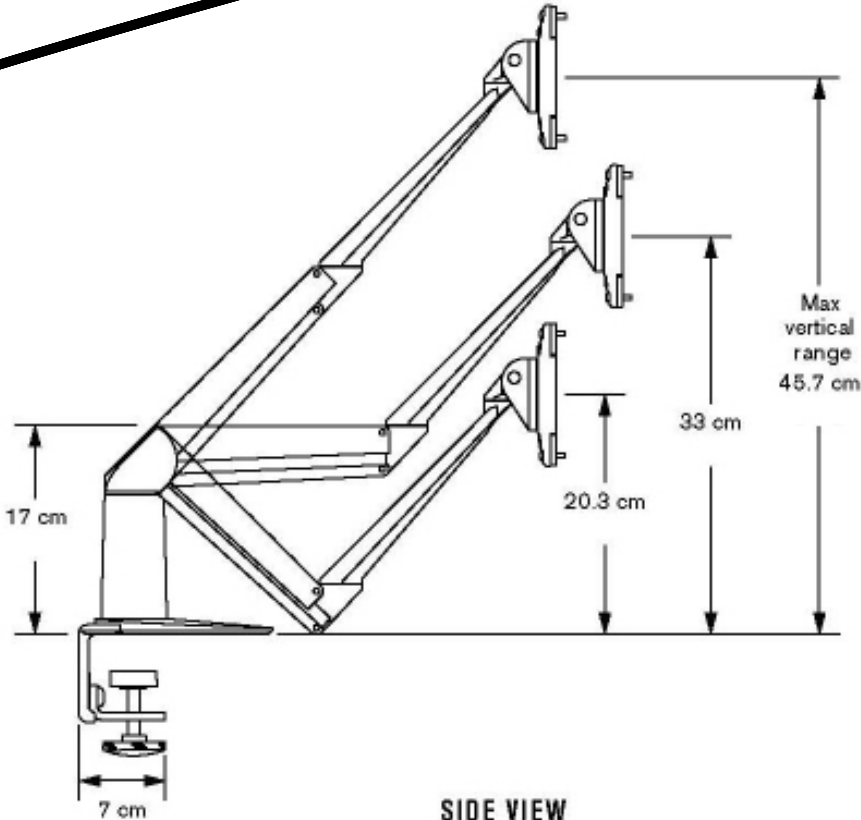

SIDE VIEW
 Vertical Range

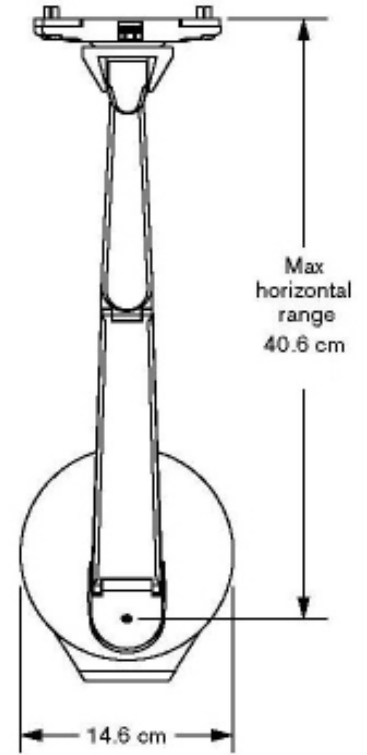

TOP VIEW
 Horizontal Range

- Suitable for monitors sized 15" to 24"
- Vertical range: +/- 46 cm from horizontal
- Horizontal range: 40.6 cm
- Rotation: 360 degrees at three joints
- Monitor tilt: 185 degrees
- Monitor pivot: Landscape to portrait
- Monitor compatibility: VESA® 75mm and 100m
- Cable management: Cables are clipped beneath arm
- Mounting options: Desk Clamp (5 cm thickness or less)
 Grommet Mount (5 cm thickness or less)
 Thru-Desk (5 cm thickness or less)
- Monitor weight: 2.7 - 5.9 kg (Model number 5545-250N)
 5.9 - 9.5 kg (Model number 5545-450N)

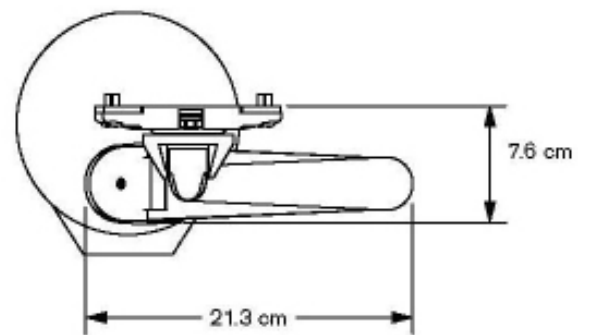

TOP VIEW
 Arm Folded